

The use of 3D Accelerometer – And Gyro Sensors in Smartphones to Measure the Blasthole Deviation in Non-Magnetic Rock

Vinicius Miranda

O-Pitblast CEO, IT Director and FEUP (Faculdade de Engenharia da Universidade do Porto – Mining Engineering PhD Student, Porto, Portugal

Francisco Leite

O-Pitblast COO, Tech. Serv. Director Porto, Portugal

ABSTRACT: Blast results are directly associated to drilling accuracy and, because it affects fly rocks, fragmentation and floor level, it must be controlled to improve the production and minimize safety impacts. Safety control is one of the most important procedures in blasting since it can affect not only the working personal but also surround communities. With the easy access to technology on the present days, the authors decided to investigate the possibility to use a personal device to measure the blasthole (less complex, easy to use and cheap). This case of study presents the comparison of hole deviation results, made by traditional equipment, in comparison with the phone's. For the validation of this new methodology 8 holes were measured (123 measured points) via the normal procedure and by the phone deviation unit. Was made a statistic analysis for the validation of the data from two different sources. From the performed analysis, to prove the validity of this new methodology, the normality tests for statistics residues analysis proves that it is possible to infer that the model has null residual mean and a small residual error. With the results achieved, showing the accuracy of these devices (less than 8cm for a hole with length up to 10m/32,80 feet, compared with the traditional device), the authors pretend to show to potentiality of this technology, the next improvements and open a completely new door for holes deviation analysis.

1 INTRODUCTION AND LITERATURE STUDY

As defined by Giraudi, Cardu, & Keckojevic (2009), the main objective of a blasting process is rock fragmentation. One of the most important actors in this process is the drilling procedure which, when properly planned can generate important economies for a mining operation (Martin, 2004). It also can minimize risks such as fly-rock which, when not receive the proper consideration can cause serious problems to a mining operation (Giles & Roller, 2012). Some efforts, as the proposal made by Orive, Laredo, Domingo, & Sadek (2017), have been made to develop new solutions for drilling and blast control. Some of it use technology available in modern smartphones such as the one mentioned by Carvalhinha Alves Sobral (2017) or the one revealed by Miranda & Leite (2018) that uses smartphones sensors to estimate the attenuation law. Following this trend, the authors of this work created an application that uses smartphones to measure hole deviations. This article presents the potentialities of this new solution.

1.1 Drilling

When discussing about economics on rock blasting, there is no way to put aside the drilling process. In one hand, there are several factors affecting economically the drilling process, such as diameter, borehole length and type of rock, in the other is the explosive selection that best fit hole and operation characteristics (Holmberg, Lee, & Person, 1994).

The purpose of this methodology is to open holes in the rock mass, with the adequate geometry in order to generate the optimum distribution of explosive energy (Jimeno, 2017).

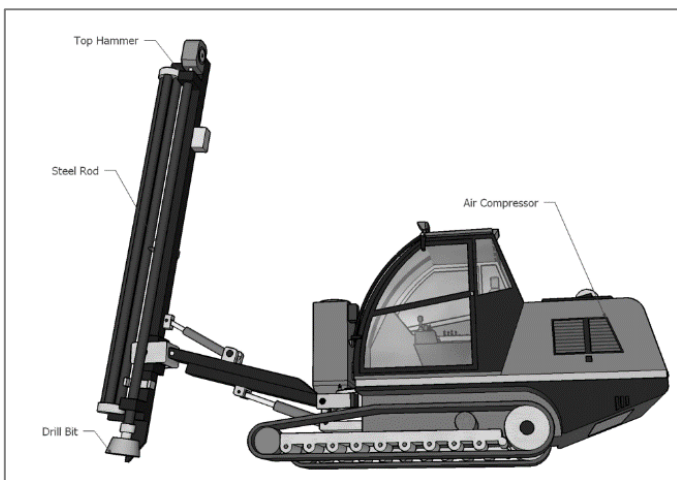

Figure 1 – Drilling machine

There are two main drilling methods: rotary-percussion (most widely used – top or down-the-hole hammer) and rotary method. In general, a drill rig is composed by a drilling bit attached to a single, or

multiple steel rods and a pressurized air system that allows the extraction of the drilling cuts – Figure 1.

1.2 Drilling Deviation

The drilling process is laden with human errors and is common to see holes being drilled quite differently from the plan. Among several reasons, to explain these events, the authors quote the article *Drill Accuracy* (1999) that mentioned that production demands or timing schedules are one of the main causes affecting drilling accuracy. When a hole suffers an unintentional deviation of the drill bit from a planned borehole trajectory, it's called borehole deviation or drilling deviation. The deviation of the bit from the desired path can induce to serious problems like higher drilling costs, fragmentation issues, floor irregularities, safety issues (fly rocks) or serious damage to the instrument (Harris, 1999).

There are two main errors when the subject is holes deviation: collar position errors and angular or bending deviations (Figure 2). The first case happens when the drill bit is positioned in a different location than the plan and the other is related with the error in terms of drilling angle and also the tendency of the steel rod to bend while the bit is progressing inside the rock mass (Leite, 2013).



Figure 2 - Typical drilling errors

To many authors, like Orpen (2007), drilling deviations can be caused due to several reasons like:

- Heterogeneous nature of formation and dip angle;
- Type of rods and tooling;
- Set-up of the drill rig and its location;
- Drill string characteristics;
- Stabilizers (location, number, and clearances);
- Applied weight on bit;
- Hole-inclination angle;
- Drill-bit type and its basic mechanical design;

- Hydraulics at the bit;
- Hole diameter;
- Improper hole cleaning;
- The experience of the driller;
- The quality of the equipment.

1.3 Drilling deviation measurements

1.4 Borehole deviation measurement devices

As remarked by Sandhaus & McClure (2012), an accurate measurement of a borehole plays an important role on the identification of deviations and potential problems. There are several instruments in the market that allows the modeling of holes profiles which provide important information for blast engineers, in order to prevent safety and production issues. Too small burdens can enable the identification of fly-rocks risk which is a major concern in terms of safety. It is also a production issue because by controlling them is possible to minimize safety zones and reduce machinery movement in blasting time, optimizing the mining/quarries personal shifts – Figure 3.

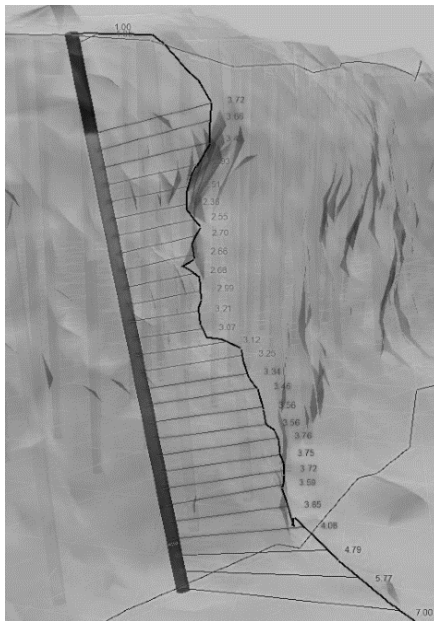

Figure 3 – Borehole profile

Besides the mentioned issues, borehole profile survey allows the control of:

- Toe generation
- Over excavation
- Wall stability
- Powder factor distribution
- Drilling operation follow up

Renishaw Boretrak® is a commercial and common instrument to measure blasthole deviations in quarries and open pits according to two different measurement principles non magnetic or magnetic minerals. There are two principal types of borehole deviation measurement units: supported with rods or a cable – Figure 4.

The first one is applied to survey holes in metal operations since it is based in inclinometers (free of



Figure 4 - Rodded and Cable Boretrak®

any kind of magnetic interference). They are also used for upholes control in underground operations.

In general, these devices had accuracy of $0,1^\circ$ and can measure holes with inclination up to 45° .

A cabled borehole analysis unit is based on a digital compass and a dual axis tilt sensor so that is limited to non-ferromagnetic operations. However, is a more portable system and very effective (Renishaw, 2017).

2 MOBILE PHONE SENSORS

This investigation was based on two technologies present on Samsung Galaxy S8 (an accelerometer and a magnetic sensor).

Some of the characteristics of the smartphone (Galaxy S8) are presented in Table 1.

For this study the phone accelerometer was used as a resource to measure the deviation. In this case, the sensor present in the mobile phone was a LSM6DSL produced by STMicroelectronics®. This electronic element is a system-in-package performing at 0.65 mA in high-performance mode and enabling always-on low-power features for an optimal motion experience for the consumer. This accelerometer can register accelerations between $\pm 2g$ and $\pm 16g$ with an output data rate of 1.6Hz to 6.6kHz and operates on the temperature range from -40°C to $+85^\circ\text{C}$ (STMicroelectronics, 2017). It was also used a magnetic field sensor produced by Asahi Kasei Microdevices Corporation (AKM). The model present in the Galaxy S8 is AK8963 that is defined as: “a 3-axis electronic compass IC with high sensitive Hall sensor technology”. This device includes a 3-axis magnetometer, an output data resolution of $0.15\mu\text{T/LSB}$ typ and a measurement rang of $\pm 4900 \mu\text{T}$. This model operates on temperature ranges from -30°C to $+85^\circ\text{C}$ (AKM, 2017).

Table 1 - Galaxy S8 characteristics

Galaxy S8 Characteristics		
Body	Dimensions	148.9 x 68.1 x 8.0 mm
	Weight	155 g
Display	Type	Quad HD + Super AMOLED 570 ppi
	Size	5.8 inches
	Resolution	2960x1440 pixels
	OS	Android 7.0
Platform	CPU	Octa-core (2.3GHz Quad + 1.7GHz Quad)
	Memory	Internal 4GB RAM (LPDDR4)
Sensors		Iris sensor; Pressure sensor; Accelerometer; Barometer; Fingerprint sensor; Gyro sensor; Geomagnetic sensor; Hall sensor; HR sensor; Proximity sensor; RGB Light sensor
Battery	Capacity	3000mAh

3 METHODOLOGY

3.1 Phone app

To build the prototype two mobile applications were developed using Android Studio 3. The first one was developed to periodically read the sensors (once every second) from the phone, treat the data to obtain an azimuth and an inclination of each measurement and save it on the phone's internal storage.

The second application receives inputs from the user such as the hole number, offset and step information.

3.1.1 Deviation Measuring Application

Although the Android code of the application is compatible with phones from Android 4.1 and up, the application was developed with the Galaxy S8 in mind. The interface has action buttons, "Start" and "Stop" (Figure 1). Once pressed "start", the phone initializes the sensors using "SensorManager" and starts registering the information every second using a timer. The sensor manager refreshes a variable every time a change in inclination or heading is detected. Due to the high precision of the sensors, several small changes are detected during every second. At the end of every second, an average is made with all the values in order to attenuate measuring spikes. The data is then converted into real world units (Heading Azimuth and Angle of Inclination) in addition to the time of the measurement.

When pressed the "Stop" button, the phone disables the sensors and the timer and saves all the values measured into the phone's internal storage.

3.1.2 Control Application

This application does not have any phone requirements since it does not use any specific hardware.

The operation principle is similar to the Rodded Boretrak® control unit. The user is able to define the hole offset, hole number and stepping size. There are four buttons on the phone screen. "Start", "Register", "End" and "Sync Data".



Figure 1 - Smartphone app for borehole control

After defining the hole number, stepping and offset, the user clicks "Start" to initiate the borehole measuring. Every time the button "Register" is pressed, the application saves the current phone time. When the measuring is done, the user presses the button "End". A file is created with the borehole number, stepping, offset and the time each measurement took place. This process is repeated for every borehole measurement.

3.1.3 Matching the Data of the Two Applications

At this point, the user has the deviation information for every second the Deviation Measuring Application was activated, as well as the information of each hole and the times with meaningful data inside Control Application.

To mix the information an algorithm was created that loops through the data captured with Control Application matching the inclination and heading information captured by the Deviation Measuring Application¹. The end result is a file that contains the borehole data (borehole number, stepping and offset as well as all the measured steps with inclination, heading and time of measuring). The file can then be imported to a blast design software.

¹ Both phones clocks are synced with the same NTP (Network Time Protocol) server so the error in time registering is not significant.

3.2 Phone Casing

In order to establish a protocol to introduce a phone inside a drilled hole, a waterproof case was designed - Figure 2. This prototype capsule allowed to keep the phone intact and slide it along the borehole. The cable attached to the case was marked every meter to set up the interval for measurements.

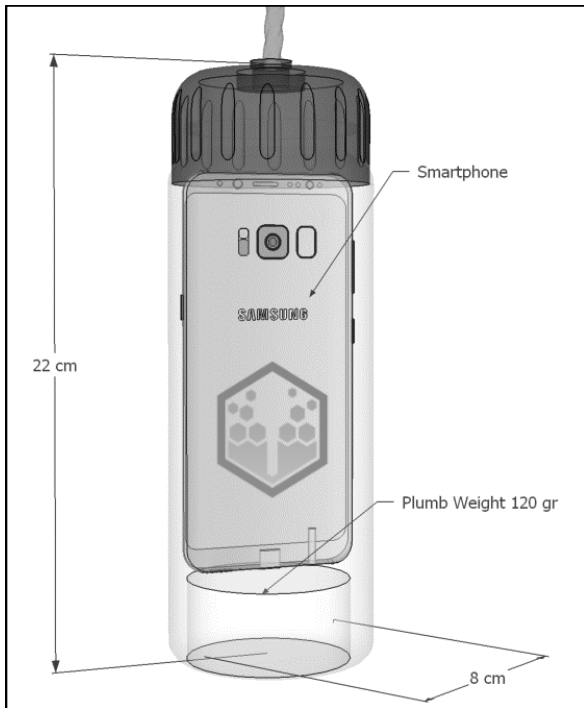

Figure 2 - Down the hole case

On the table Table 2 are presented the blast geometrical parameters. In Figure 4 the drilling plan is shown.

Table 2 - Blast design parameters

Parameters	Value
Bench High	10,0 m
Diameter	89,0 mm
Burden	3.2 m
Spacing	3.2m
Subdrilling	1,0 m
Stemming	2,7 m

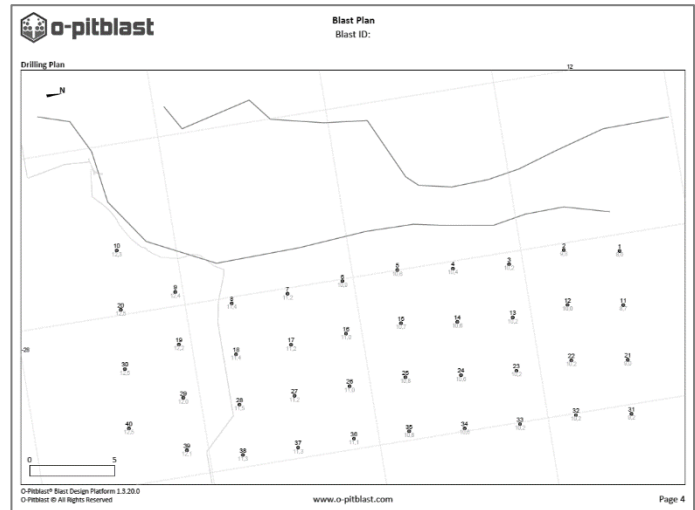

Figure 4 – Design blast

3.3 Field procedure

The field test was carried out in a Portuguese quarry explored by DST Group – Tagregados. The field tests included:

- Scan of the free face (Figure 3);
- Register holes position;
- Measurement of hole's profile with Rodded Boretrak®;
- Measurement of hole's profile with the smartphone app;



Figure 3 - Laser 3D scan

3.4 Data analysis

Several data was recorded, inside of the borehole, at different positions (see **Error! No se encuentra el origen de la referencia.**). First, the interval between measurements (usually 1 meter, but can assume any natural value greater than 1) is defined. It will be necessary $[(Hole\ Length)/interval]$ measurements. In case of the hole having a size that is not multiple of the interval, the difference between the position of the first measurement and the remaining will be different. This difference is usually called off-set, while the other measures will have a differ-

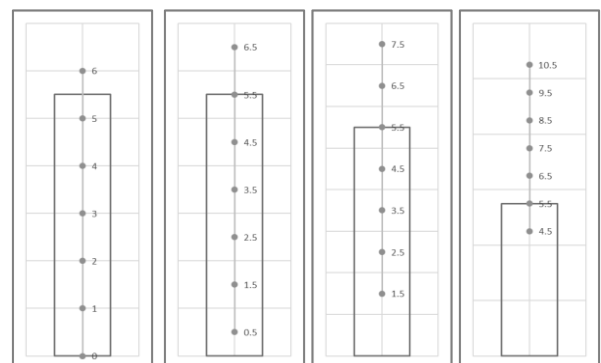

ence that is equal to the interval adopted.

Figure 9 – Position the equipment along the hole

Table 3 reports to a set of data record in one borehole.

Table 3 - Borehole measurements

Position (Z)	Inclination (°)	Azimuth (°)	Δz (m)
10,5	2	23	1
9,5	2	24	1
8,5	3	24	1
7,5	4	23	1
6,5	4	24	1
5,5	3,5	22	1
4,5	7	19	1
3,5	5	23	1
2,5	8	24	1
1,5	6	24	1
0,5	6	23	0,5

It is assumed that the coordinate (0,0,0) is the local collar position of each hole.

Then, the vector u is defined as:

$$u = (0,0,-1) \times \Delta Z$$

To the vector u are applied two rotations²: one rotation in the X axis to get the hole inclination and another one in the Z axis to get the azimuth (an illustration can be seen in **¡Error! No se encuentra el origen de la referencia.**

The azimuth rotation needs to be done in clockwise due to the reverse direction of the azimuth progressing compared with a normal rotation matrix bidimensional. The process is described below.

It's assumed that:

$$\begin{aligned} \theta &= \text{inclination} \\ \alpha &= -\text{azimuth} \end{aligned}$$

The first rotation:

$$R^1 = \begin{pmatrix} 1 & 0 & 0 \\ 0 & \cos \theta & -\sin \theta \\ 0 & \sin \theta & \cos \theta \end{pmatrix}$$

The second rotation:

$$R^2 = \begin{pmatrix} \cos \alpha & -\sin \alpha & 0 \\ \sin \alpha & \cos \alpha & 0 \\ 0 & 0 & 1 \end{pmatrix}$$

A point will be found in space and added to our list of points:

$$\text{New point} = \text{last point inside list} + R^2 \times R^1 \times u'$$

² For more details on linear transformation and rotations see chap 5 of Boldrini, Rodrigues Costa, Figueiredo, & Wetzler (1980)

A “new point” is added to the list of real points and this task is repeated until the lines of the table are over.

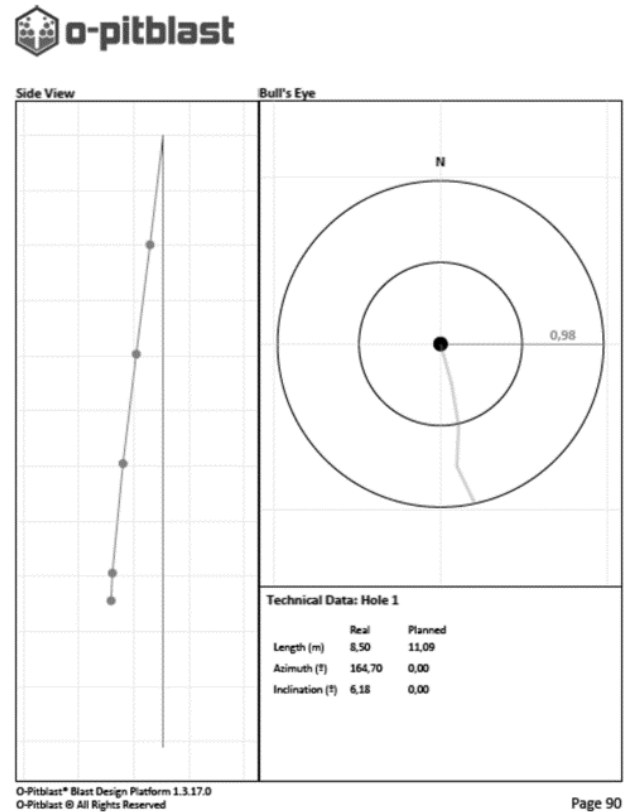
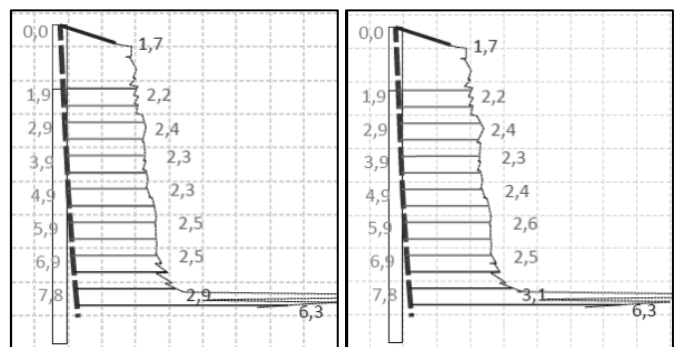

Figure 10 - Example of data with two rotations, extracted from O-Pitblast ®

4 RESULTS DISCUSSION

4.1 Comparison

After measurement of the holes in the field using both devices (rodded boretrak® and the smartphone device) the first step was plot both information in a software with the capability to read the data. Was selected the O-Pitblast®³ and after the treatment of the data two reports were generated to compare it - Figure 5.



³ O-Pitblast, 2018

Figure 5 - Visual comparison between both systems (in the left side the Boretrak® system).

It is possible to observe that the two profiles, in a first view, are identical. The main idea behind this comparison is to check that both profiles are equal (different results on the measurement would generate different profiles) and have the same (or closer enough) burden across all the length of the borehole.

Table 4 - Numerical results of the burdens were taken, and the residue was calculated

Boretrak depth (m)	Boretrak burden (m)	Phone depth (m)	Phone burden (m)	Residue (m)
0	1,72	0	1,72	0
1,89	2,17	1,89	2,18	-0,01
2,39	2,18	2,39	2,2	-0,02
2,88	2,36	2,88	2,42	-0,06
3,38	2,29	3,38	2,33	-0,04
3,88	2,29	3,87	2,32	-0,03
4,37	2,32	4,37	2,35	-0,03
4,87	2,34	4,87	2,37	-0,03
5,36	2,51	5,36	2,55	-0,04
5,86	2,52	5,86	2,56	-0,04
6,36	2,49	6,35	2,53	-0,04
6,85	2,49	6,85	2,52	-0,03
7,35	2,7	7,35	2,7	0
7,85	2,95	7,84	3,06	-0,11

Is possible to check it by analyzing the Table 4 using the burden calculated in different positions on the borehole.

Is reasonable conclude that the smartphone system generated results as good as the captured by traditional devices. Only with this comparison it is not possible (at least not strictly) to qualify the result, and therefore is necessary (at least) to do a residue analysis (Miranda, Leite, Jesus, & Sobral, 2017).

4.2 Statistical analysis

The first step was to do a descriptive analysis of the data. The result is shown on Figure 12:

Descriptives			Statistic	Std. Error
Residue	Mean		,0077	,04200
	95% Confidence Interval for Mean	Lower Bound	-,0754	
		Upper Bound	,0909	
	5% Trimmed Mean		-,0242	
	Median		-,0200	
	Variance		,217	
	Std. Deviation		,46580	
	Minimum		-2,07	
	Maximum		2,69	
	Range		4,76	
	Interquartile Range		,05	
	Skewness		3,035	,218
	Kurtosis		24,333	,433

Figure 12 - Descriptive analysis of the residue

A first analysis could indicate that the results apparently are good due to the zero inside the confidence interval for the mean and the histogram concentrated around the zero (Miranda, 2016). Plus, it's possible to conclude that both data comes from the same sample (i.e. they are identical). But following the analysis the graph present in Figure 8 was generated.

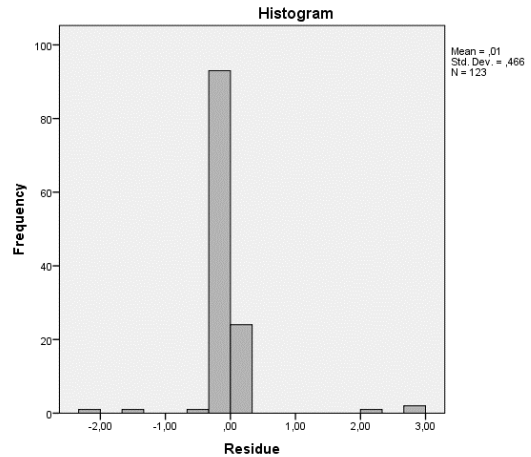

Figure 7- Histogram of the residue concentrated around the zero.

	Kolmogorov-Smirnov ^a			Shapiro-Wilk		
	Statistic	df	Sig.	Statistic	df	Sig.
Residue	,390	123	,000	,350	123	,000

a. Lilliefors Significance Correction

Figure 64 - Normality test

Case Processing Summary						
	Cases					
	Valid		Missing		Total	
	N	Percent	N	Percent	N	Percent
Residue	123	100,0%	0	0,0%	123	100,0%

Figure 15 - Case Processing Summary

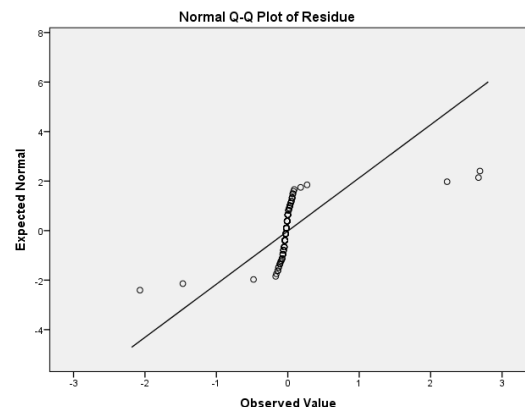

Figure 8 - Normal Q-Q Plot of the residue indicating that residue doesn't follow a normal distribution

Is possible to verify that the data has a different behavior not expected by *Miranda (2016)* and also by *Gujarati (2010)*⁴. Furthermore, it goes in the opposite direction of the central limit theorem.

Probably it comes from the presence of outliers, hidden by the histogram analysis but visible in the boxplot (Figure 17Figure 9).

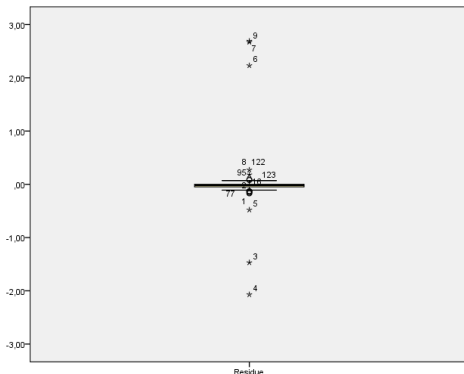

Figure 97: Boxplot indicating the presence of outliers.

We can clearly see points far out of the third quartile, much more than 1.5 times the difference between the third and first quartile (criteria stronger enough to classify this data as outliers – (Gama, Carvalho, Faceli, Lorena, & Oliveira, 2017)).

After removing the 9 worst cases (from a total of 123 records) – in agreement with the outlier detection methodology proposed by *Czaplicki (2014)* - the data was re-evaluated. The result is shown in Figure 18.

	Cases					
	Valid		Missing		Total	
	N	Percent	N	Percent	N	Percent
Residue	114	100,0%	0	0,0%	114	100,0%

a. OUTLIER = NORMAL

Figure 1810 – Case Processing Summary

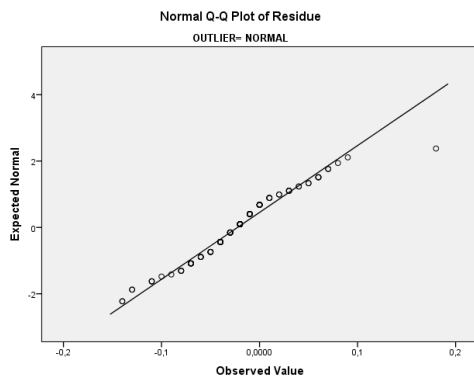

Figure 19 - Histogram of the residue after remove the outliers.

⁴ Although the *Gujarati* statement is related to linear models, the authors of this research expand the interpretation (with due precaution) to generic models (*Miranda & Leite, 2017*)

Descriptives^a

		Statistic	Std. Error	
Residue	Mean	-,0225	,00465	
	95% Confidence Interval for Mean	Lower Bound	-,0317	
		Upper Bound	-,0132	
	5% Trimmed Mean	-,0231		
	Median	-,0200		
	Variance	,002		
	Std. Deviation	,04965		
	Minimum	-,14		
	Maximum	,18		
	Range	,32		
	Interquartile Range	,05		
	Skewness	,485	,226	
	Kurtosis	2,103	,449	

a. OUTLIER = NORMAL

Figure 2011 - Descriptive analysis of the residue after remove the outliers.

Tests of Normality^a

	Kolmogorov-Smirnov ^b			Shapiro-Wilk		
	Statistic	df	Sig.	Statistic	df	Sig.
Residue	,124	114	,000	,959	114	,001

a. OUTLIER = NORMAL

b. Lilliefors Significance Correction

Figure 21 - Normality test (the null hypothesis was rejected)

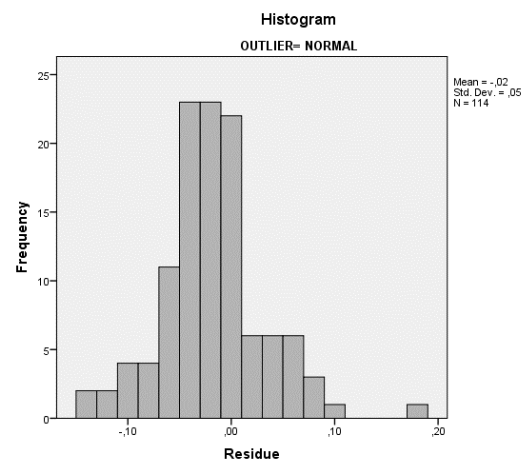

Figure 22 - Normal Q-Q Plot

Here, one more time, the statistical hypothesis testing rejected the null hypothesis, but it's possible to reproduce the *Moreira's* explanation⁵ that defends the use of all information available to decide or reject the normality, and not only the statistical hypothesis.

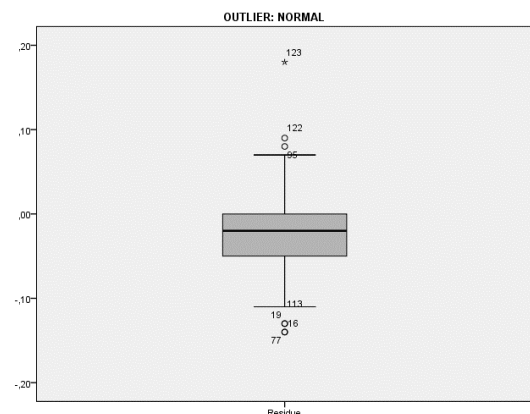

Figure 12 - Boxplot

⁵ *Moreira, Macedo, Costa, & Moutinho, 2011, p. 57*

Comparing the sampled quartiles with the Normal distribution quartiles is possible to conclude that they are similar. The histogram has the shape of a Normal distribution and is symmetric enough around the mean. Finally, it's evaluated the boxplot in Figure 23.

Now, with the data treated, it's possible to verify that exists evidence enough to conclude that, using the smartphone system, the mean of the residue (comparing with traditional methodology) will be (for 95% of statistical confidence) lower than 3 cm and the standard deviation lower than 5 cm. Based on this, it's possible to conclude that exist statistical evidence for a maximum error of the new system under 8 cm.

5 LIMITATIONS

Although the positive results presented on the investigation is prudent refer some limitation identified during the field test process. Diameters under 79,00 mm/ 3,11 inches can limit the entrance of the case containing the smartphone. It is essential the usage of a waterproof case to avoid water infiltration. In terms of application, this methodology is limited to non-magnetic mines since this element will clearly affect the magnetic sensor. Though the number of analyzed samples shown an indicative of a normal distribution of the residue, and the authors defend the need to collect more field data.

6 CONCLUSIONS

The use of new technology to support blast/drilling operations is playing an important role in terms of production and safety. This study proved that with a simple smartphone it is possible to model a borehole shape and treat that information immediately after the analysis. The equipment is quite practical to use, and the training required is minimum. The price (600,00€ aprox.) is more attractive to medium and small operations, however more tests and analyses are needed.

7 ACKNOWLEDGEMENTS

The authors would like to gratefully thank to DST Group - Tagregados, specially to Diogo Fonseca, for the opportunity given to carry out this project in DST Quarry. Raquel Sobral (O-Pitblast Technical Services Engineer) and Pedro Brito (O-Pitblast IT Engineer) are acknowledge outstanding support on the field procedure, patience, and excellent job on the development of the control app. We would like to thank the Oporto University - Engineering Faculty (Mining Department - FEUP), specially to Engineer Alexandre Leite and Engineer José Soeiro de Carvalho and

Pernambuco Federal University, particularly Prof. José Carlos. Also to Alan Lacerda (Mining Engineers) for the support on the field procedures. A special thanks to Rosa and Carolina for the patience.

8 REFERENCES

- AKM. (2017). *AK09916C*. Obtenido de Asahi Kasei Microdevices Corporation: <https://www.akm.com/akm/en/product/datasheet1/?partno=AK09916C>
- Bhandari, S. (1997). *Engineering Rock Blasting Operations*.
- Boldrini, J. L., Rodrigues Costa, S., Figueiredo, V. L., & Wetzler, H. G. (1980). *Álgebra Linear*.
- Brito, P. (10 de January de 2018). Obtenido de O-Pitblast: www.o-pitblast.com
- Carlson. (2016). *Carlson Boretrak® borehole-deviation measurement system*. Obtenido de Carlson: Break New Ground: <http://www.carlsonsw.com/products/laser-measurement-devices/cabled-boretrak/>
- Carvalhinha Alves Sobral, R. (2017). *Seismo: Desenvolvimento de uma aplicação para análise de vibrações em desmonte de rochas*. Porto: FEUP.
- Czaplicki, J. M. (2014). *Statistics For Mining Engineering*. London UK: CRC Press.
- Gama, J., Carvalho, A., Faceli, K., Lorena, A., & Oliveira, M. (2017). *Extração de Conhecimento de Dados*. Sílabo, Lda.
- Giles, E., & Roller, E. (2012). Flyrock Elimination Program Part 2: Profilers and Boretracks. *ISEE: International Society of Explosives Engineers*.
- Giraudi, A., Cardu, M., & Kecojevic, V. (2009). An Assessment of Blasting Vibrations: A Case Study on Quarry Operation. *American Journal of Environmental Sciences*, 468-474.
- Gujarati, D. &. (2010). *Econometría*. McGraw-Hill/Interamericana Editores, S.A. de C.V.
- Harris, J. E. (12/08/2017 de Mar de 1999). Drill Accuracy. *ISEE: International Society of Explosives Engineers*. Obtenido de [www.support.apple.com: https://support.apple.com/kb/SP685?locale=pt_PT&viewlocale=es_ES](https://support.apple.com/kb/SP685?locale=pt_PT&viewlocale=es_ES)
- Holmberg, R., Lee, J., & Person, P.-A. (1994). *Rock Blasting and Explosives Engineering*. CRC Press, Inc.
- Jimeno, C. L. (2017). *Manual de Perforación, Explosivos y Voladura*.
- Lashinsky, A. (2012). *Inside Apple: How America's Most Admired--and Secretive--Company Really Works*. Business Plus; First Edition edition.
- Leite, F. S. (2013). *Desarrollo de una Herramienta de diseño de Túneles*.

- Martin, P. L. (2004). Drill and Blast Optimization at the Sparkhule Limestone Quarry. *ISEE: International Society of Explosives Engineers*.
- Miranda, V. (2016). Validação de Modelos Lineares: Uma Análise Residual. Porto, Portugal.
- Miranda, V., & Leite, F. (2018). Vibration Control using an iPhone - Accuracy, validation and potentialities. *ISEE: International Society of Explosives Engineers*.
- Miranda, V., Leite, F., Jesus, C., & Sobral, R. (2017). A new Approach to 3D Modeling of Blast Free Faces. *International Society of Explosives Engineers - 43rd Annual Conference on Explosives & Blasting Technique - Orlando, Florida, USA*.
- Moreira, A., Macedo, P., Costa, M., & Moutinho, V. (2011). *Exercícios de estatística com recurso ao SPSS*. Lisboa: Sílabo, Lda.
- Orive, J., Laredo, R., Domingo, J., & Sadek, J. (2017). Innovation in up-hole deviation measurements in sublevel stoping mines. *EFEE: European Federation of Explosives Engineers*, 397-404.
- Orpen, J. (2007). Introducing the borehole surveying benchmarking project. *Institute of Mine Surveyors of South Africa*, 507-512.
- Renishaw. (2017). *Rodded Boretrak® and Cabled Boretrak®*.
- Samsung. (2017). *Samsung*. Obtenido de Samsung: <http://www.samsung.com>
- Sandhaus, B., & McClure, R. (2012). Flyrock Elimination Program Part 3: 3D Bench Photogrammetry. *ISEE: International Society of Explosives Engineers*.
- STMicroelectronics. (2017). *STMicroelectronics*. Obtenido de STMicroelectronics: <http://www.st.com>